

LIFTING LUGS

EXTERNAL EARTH POSITION.

CABLE ENTRY SCREWED 3" N.P.T.

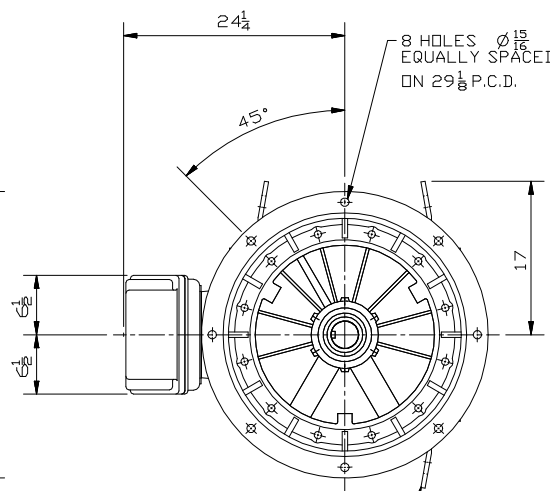

8 HOLES EQUALLY SPACED ON 29 1/8" P.C.D.

THIS LIFTING LUG FITTED ONLY WHEN MOTOR IS VERTICALLY MOUNTED.

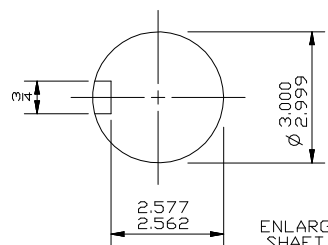

ENLARGED VIEW OF SHAFT EXTENSION

NOTE:-
 TERMINAL BOX CAN BE TOP OR RIGHT HAND SIDE MOUNTED BY REFITTING FEET 90° IN APPROPRIATE DIRECTION.
 CABLE ENTRY CAN BE SUPPLIED IN ANY ONE OF FOUR POSITIONS AT 90° INTERVALS.

CUSTOMER	
ORDER No.	
SERIAL No.	
FRAME SIZE	
HP	R.P.M.
Hz	PHASE 3
VOLTS	POLES
BRGS. D.E	N.D.E
MOTOR NETT. WT. Kg.	
INSULATION CLASS	
TEMPERATURE RISE °C	
DESIGN AMBIENT TEMPERATURE °C	
HEATER WATTS & VOLTS (IF FITTED)	
WATTS,	VOLTS

REMARKS

Large Industrial Motors
Guisley, LEEDS LS20 9NZ

ALL DIMENSIONS IN INCHES

THIRD ANGLE PROJECTION

BROOK CROMPTON

Large Industrial Motors
GUISLEY, LEEDS, LS20 9NZ.

NOTE!
 ENDPLAY WILL BE PROVIDED FOR ENDTHRUST PROTECTION WHEN CUSTOMERS NOTIFY US OF THEIR INTENTION TO USE RIGID COUPLINGS AND DRIVEN MACHINES WITHOUT ENDPLAY.

OUTLINE DIMENSIONS OF STANDARD D FLANGE MOUNTED INCH A.C. MOTOR TO NEMA STD. MG1. TOTALLY ENCLOSED FAN COOLED.
 FRAME SIZE:- W-DF586SZ-D.

SCALE	1:12	DATE
DRAWN	B.J.T.	19.12.97
CHECKED	B.J.T.	19.12.97
APPROVED	I.J.W.	19.12.97

DRG. No.	M20845
REVISION:	DATE